



40 GHz SMA 2.9 fem LATCHING TRANSFER SWITCH

OPTIONS: INDICATOR / SELF CUT-OFF / TTL DRIVE

R F CHARACTERISTICS

FREQUENCY RANGE : 0 - 40 GHz
IMPEDANCE : 50 Ohms

FREQUENCY (GHz)	0 - 6	6 -12.4	12.4- 18	18 -26.5	26.5- 40
V.S.W.R <=	1.30	1.40	1.50	1.70	1.90
INSERT. LOSS <=	0.30 dB	0.40 dB	0.50 dB	0.70 dB	0.80 dB
ISOLATION >=	70 dB	60 dB	60 dB	55 dB	50 dB
AVER. POWER (*)	80 W	60 W	50 W	20 W	10 W

ELECTRICAL CHARACTERISTICS

ACTUATOR : LATCHING
NOMINAL CURRENT AT 25° C (±10%) : 320 mA
ACTUATOR VOLTAGE (Vcc) : 12V (10.2 to 13V)/ NEGATIVE COMMON
TERMINALS : solder pins (250 Deg.C max./30 sec)
INDICATOR RATING : 1 W / 30 V / 100 mA
SELF CUT-OFF TIME : 40 ms < CT < 120 ms
TTL INPUTS (E) - High level : 2.2 to 5.5V / 800µA at 5V
- Low level : 0 to 0.8V / 20µA at 0.8V

MECHANICAL CHARACTERISTICS

CONNECTORS : SMA 2.9 fem per MIL C 39012
LIFE : 2.500.000 cycles
SWITCHING TIME (nominal voltage;25° C) : < 15 ms
CONSTRUCTION : splashproof
WEIGHT : < 85 g

ENVIRONMENTAL CHARACTERISTICS

OPERATING TEMPERATURE RANGE (°C) : -40 , +85
STORAGE TEMPERATURE RANGE (°C) : -55 , +85

(* : average power at 25° C)

This information is given as an indication. In the continual goal to improve our products, we reserve the right to make any modifications judged necessary

4112-9212

DRAWING

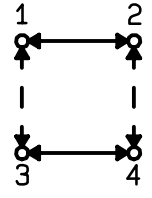
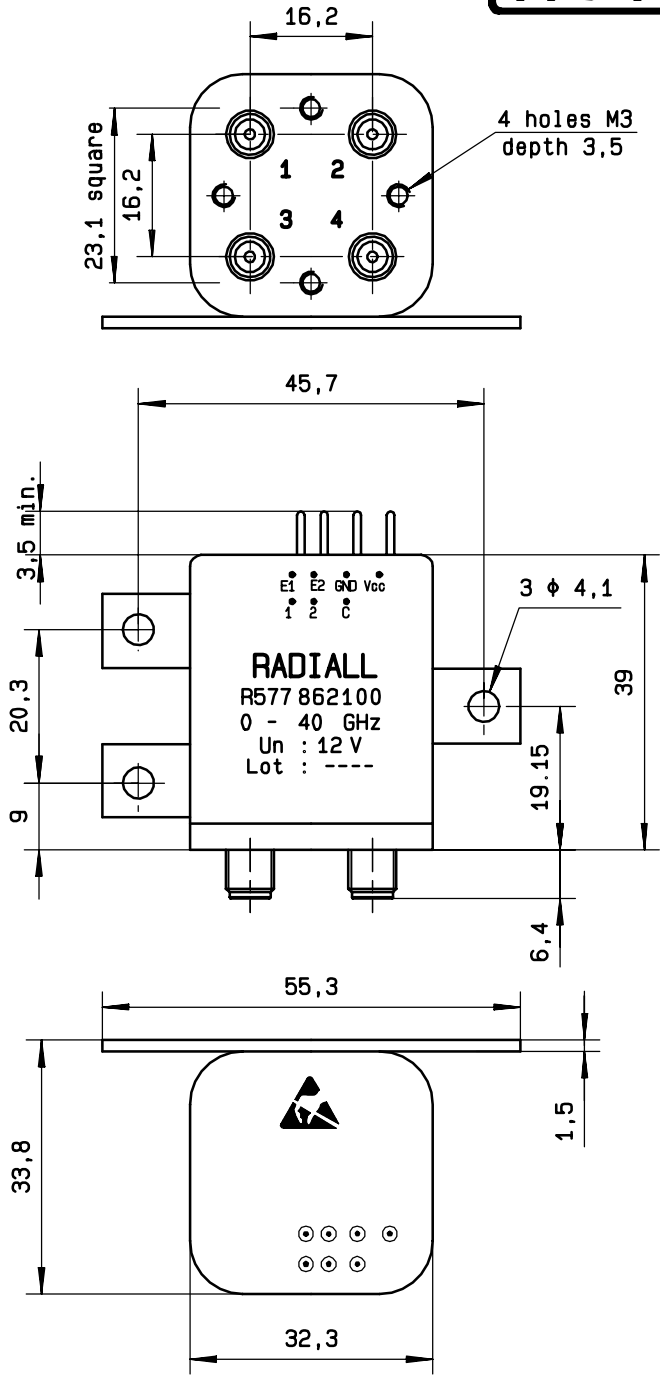

General tolerance: ± 0,5 mm

SCHEMATIC DIAGRAM

TTL input	RF continuity	Indicator
E1=1 E2=0	1 ↔ 3 2 ↔ 4	C . 1
E1=0 E2=1	1 ↔ 2 3 ↔ 4	C . 2
E1=0 E2=0	Memory	—
E1=1 E2=1	Forbidden	—

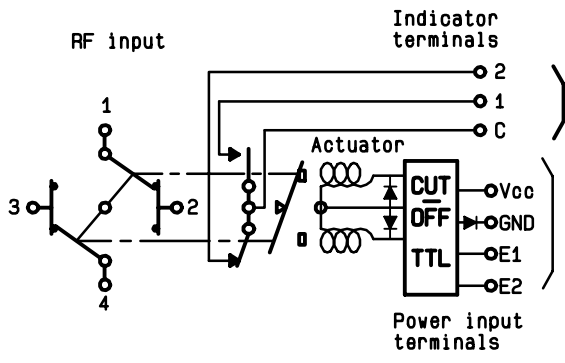

4113-9212 This information is given as an indication. In the continual goal to improve our products, we reserve the right to make any modifications judged necessary